



ACOUSTIC INSULATION FOR CONSTRUCTION



dBred
noise reduction

Edilteco Group in Italy, Europe and all over the world.



A great number of production units and a technical / commercial capillary network ensure the coverage of the entire national territory. The sale network is assisted by technicians for the shipbuilding industry and for prior certification of the building works. Abroad Edilteco is directly present in France and Belgium with its branches Edilteco France and Edilteco Benelux, in Argentina with Edilteco Sudamericana and Edilteco Iberica. Edilteco Production is also distributed, or produced, under license from industrial partners in many European, American and African countries. Infact Edilteco works with companies around the world making licensed local productions, providing know-how, special components and technical and commercial assistance.

LEGEND
● production centers
● distributors

You will be constantly updated through our website www.edilteco.it or contacting our Commercial service info@edilteco.it of division info@dbred.it

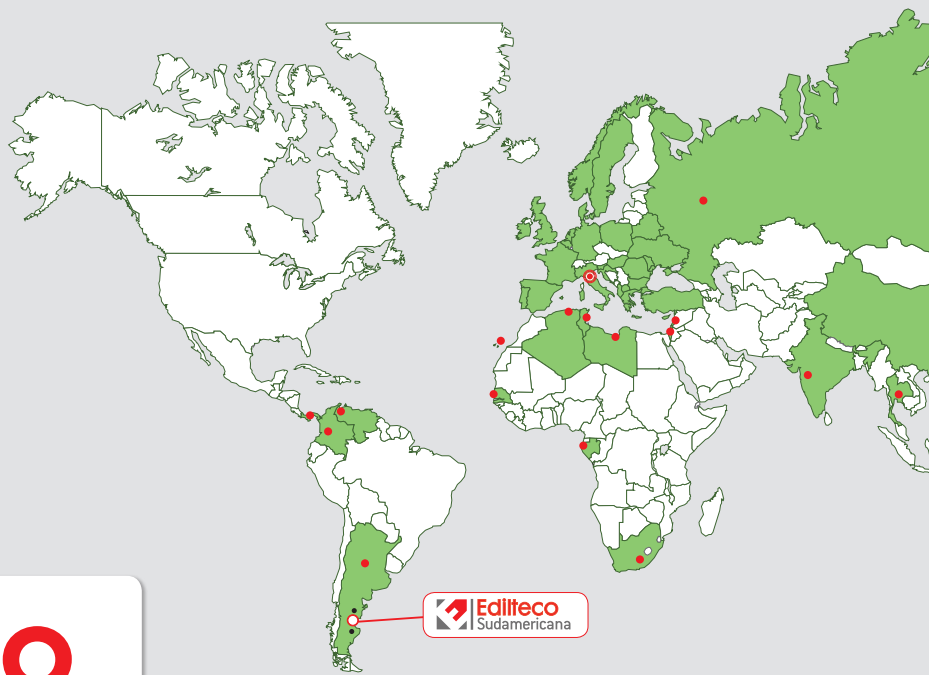

A green map of Europe and Asia is positioned on the left side of the page. The map shows the outlines of the continents, with a small red dot marking a location in East Asia.

EDILTECO GROUP

is the ideal partner to meet every need of the modern and qualified construction.

Besides ensuring the highest quality of its products, Edilteco offers a complete, fast and effective collaboration to all its partners and customers, through the synergy of its various divisions.

dBred® noise reduction is the brand with which Edilteco Group deals with acoustic insulation.

A correct acoustic design should combine the use of the most suitable products according to the environment typology and acoustic noise to which it is subjected.





In order to improve the approach of the acoustic problems in building, dBred makes available to companies and design studios, its trained, competent and highly qualified staff, able to provide compliance with the requirements

of all types of construction, through high level materials.

The dBred offer includes a wide range of mats, slabs, felts, high soundproofing power panels, rot over time, unscented, impervious to mold or microorganisms, not polluting, recyclable, resistant to pressure and to cement alkali.

introduction.

General index

	introduction	1
	Current legislation for acoustic insulation	4
	dBred materials	6
	Sustainability applied to building	7
	Impact sound insulation: product line and systems	8
	- Duetto series	9
	- F series	10
	- F-C series	11
	- Fonotech series	12
	- Wooden floating floors - systems	13
	- Felts series	14
	- Fonotech P - Fonotech ECO P	15
	- Piano ZERO - systems	16
	Impact sound insulation: Accessories	
	- LF 5 Super and Economy stripes	18
	- R-Stick adhesive tapes	19
	Air transmission noises insulation: product line, systems and accessories	20
	- W series	21
	- F3 stripes	22
	Laying instruction: dBred F series stripes	23
	- vertical and horizontal partitions - systems	24
	- ZERO dB GIPS series	26
	- Ecap ADP	27
	Vibration technology: accessories	
	- Hangers	28

CURRENT LEGISLATION FOR ACOUSTIC INSULATION

In the design phase of the buildings an accurate preliminary study on the acoustic conditions according to the results of living comfort expected by users is compulsory. In many countries of the world, there are specific national regulations with specific requirements regarding sound insulation in building. These regulations often impose the values that have to respect the passive acoustic requirements indexes of the buildings for every single element of the structure. These requirements concern the behavior of the building towards the sounds coming from the external world, or from adjacent houses and in some cases they regard also the acoustic aspects for direct noise transmission among the different rooms of the same residential unit.

THE ACOUSTIC INSULATION OF THE BUILDINGS CAN BE SCHEMATIZED AS FOLLOWS:

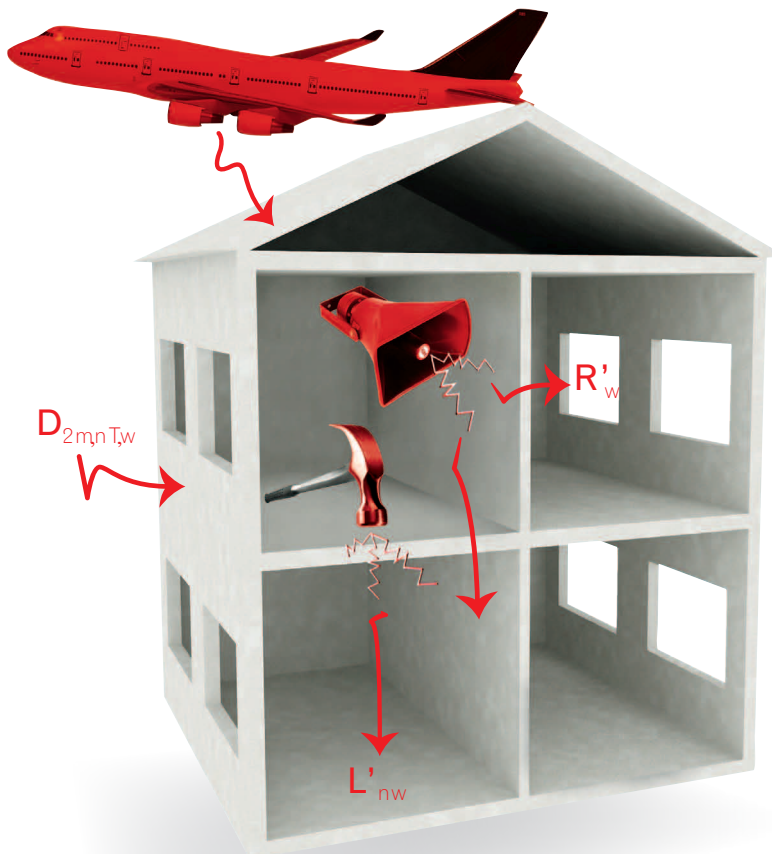

1

Airborne sound insulation from outdoors

2

Airborne sound insulation from adjacent units

3

Impact sound insulation from other units

4

Sound and Vibrations insulation of plants

The acoustic performances of the buildings are often subjected to many international technical regulations. These regulations provide the parameters suitable to every typology of noise insulation and the way they have to be measured on site or during the design phase.

As follows we report the main standards for measuring the technical characteristics of the building and the most spread indexes to verify its performances.

Type	Units	Standards	Index
Airborne sound insulation from outdoors	dB	ISO 140-5	$D_{n,w}$; $D_{nT,w}$; $D_{2m,nT,w}$
Airborne sound insulation from adjacent units	dB	ISO 140-4	R'_{w} ; $D_{n,w}$; $D_{nT,w}$
Impact sound insulation from other units	dB	ISO 140-7	$L'_{nT,w}$; L'_{nw}

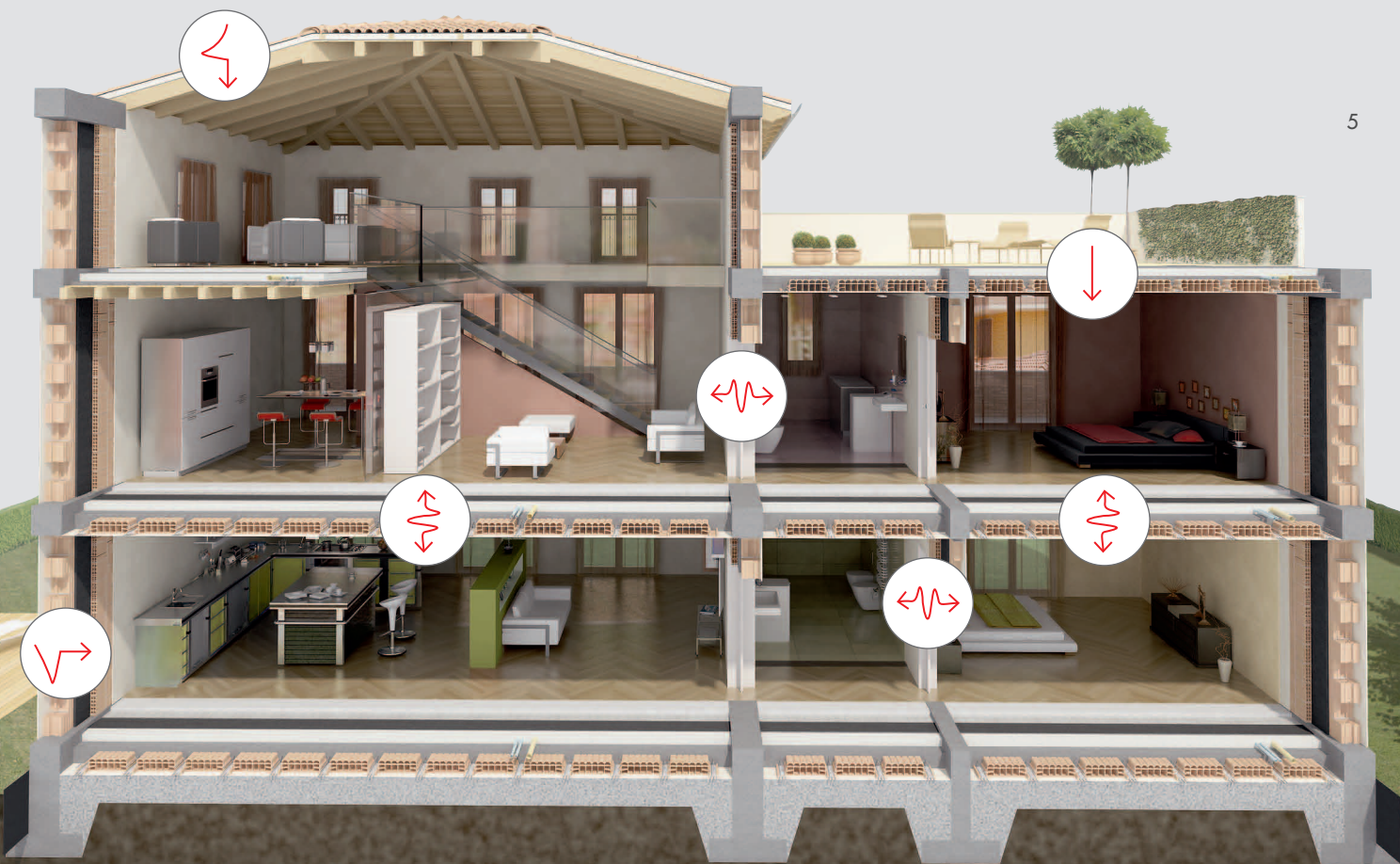

Classification of residential areas and passive acoustic requirements of the buildings

dBred materials: what they are and how they are produced.

Edilteco Group realizes a range of specific products for acoustic insulation which is distinguished for its performance and careful selection of raw material.

The cleaning and selection of raw materials (SBR rubber granules and fibers) are the basis of dBred products, as the presence of the rubber alone allows a correct industrial control of the final product specific weight.

Consequently the certainty and constancy of the performances. To achieve a high quality rubber surface it is necessary to quantify and qualify the various processes that start from a tire to obtain a finished mat. The first essential step concerns the supply of SBR rubber granules and fibers (Baffin) that must be selected, cleaned, washed and separated by type, particle size and physical characteristics. This first operation, which requires time and expertise, is essential to ensure an optimal base to obtain the final product.



6

select the aggregates according to the type of material you want to get

After the cleaning of the aggregate, the preparation of the mixture becomes essential.

It is based on the selection of inerts according to the type of material you want to get (the granule alone, granule and fiber, the fiber alone); mixing the aggregates with a special MDI polyurethane resin, you will get a mixture which will be compacted and seasoned in special moulds and then moved to the phase of cold peeling.

All the dBred rubber products are made starting from the concept of "peeling" from the raw material. It is therefore important to underline that, increasing the material density, you will have production benefits related to the speed of production and to the less material selection; however you will get products with worst physical / mechanical characteristics that can be used only for permanent heavy loads to ensure the correct functioning.



the concept of sustainability applied to construction.

In order to focus on the objectives and principles of the sustainable building rules, it is important to start from the definition of sustainability.

Sustainability means 'the mankind's ability to respond to the current needs without compromising the aptitude of future generations to meet their own needs.

The sustainable development of the building considers not only the constructions but also the individual and collective infrastructures, as well as the single products, functional components, services and processes related to their life cycle.

In an international market increasingly "green" oriented, we took in consideration the possibility to give objectivity to the requested sustainability concepts, therefore it is actually possible to observe how numerous sustainable evaluation and certification systems exist in the world.

In the world, the current legislation for the assessment of sustainable building is rather fragmented. Of course, the LEED protocol (The leadership in Energy and Environmental Design) is the most common on the international private market.

Every protocol has its specificity, contents and application modality with affinities and common points.

The protocols are based on a scoring system with a list of requirements to which is assigned an evaluation judgement, the global scoring defines the environmental sustainability of the building.

Thanks to the characteristics related to the recycled material and to the low energy impact, the dBred products range can contribute to obtain an high score according to the modalities expressed by LEED protocol.

LEED

Sections	Credits	Technical description
Energy and atmosphere	Prerequisite 2	Minimum energetic performances
	Credit 1	Optimization of the energy performances
Materials and resources (MR)	Credit 4	Recycled content
	Credit 5	Extracted, processed and produced at a limited distance materials (regional materials)

IMPACT SOUND INSULATION

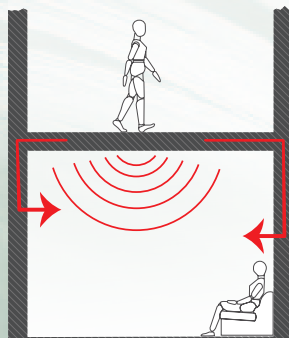

It is essential to intervene acoustically on the floor slabs of the houses, offices or buildings with other intended uses in order to avoid the transmission of impact noises which are propagated per solid way through the structures of the building. The people's trample, the accidental falling of objects or the vibrations of any eventual appliance on the floor, generate noise environment in the neighboring areas and particularly in those below.

It is therefore necessary to define the most suitable acoustic system in order to obtain the expected insulation as per the design or at least that required for compliance with the values provided by the current legislation.

The most effective solution for the reduction of impact noises on floors is to realize the floating screed system.

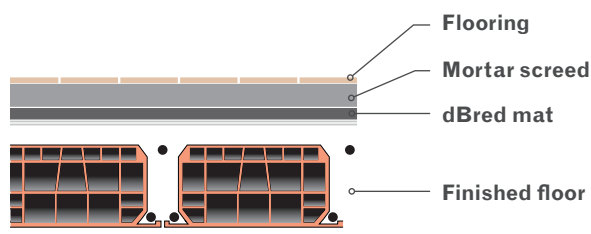

A **floating screed** system is a floating screed applied to an impact sound insulation mat, completely free from attic and vertical partitions.

Therefore it will be a system free to vibrate.



The efficacy and the correct functioning of an impact sound insulation floating screed system depends on two fundamental factors. The first is the correct design for the choice of the suitable material and the second is the correct application of the system. For the last one it is necessary the absence of hard connections with the walls, the entry and french windows. It will be necessary to verify the continuity of the installation of the impact mat and the perimetric stripes (detachment from the walls) of the coating and skirting board (see the section dedicated to the product installation).

dBred line DUETTO

thermo coupled acoustic insulation -SBI/MDI rubber + cross linked polyethylene - Rolls

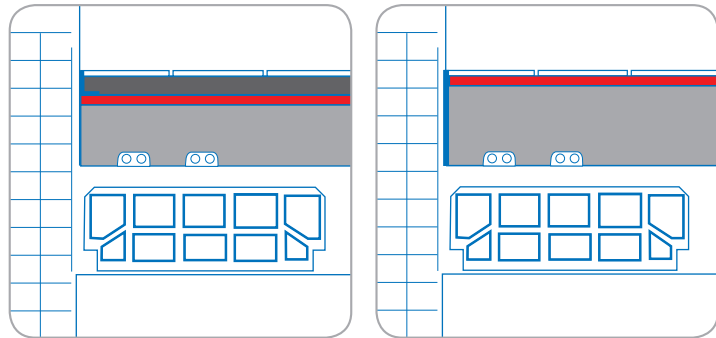
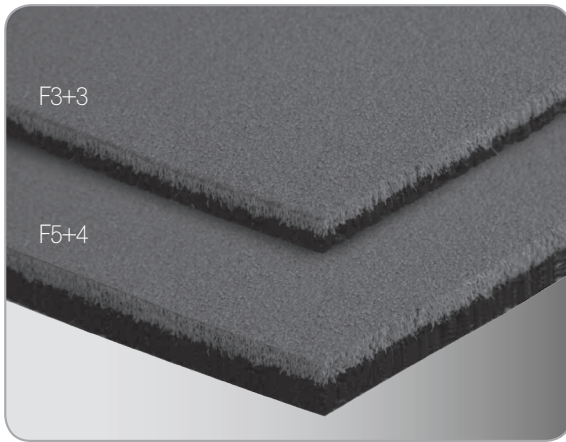

Applications

Impact sound insulation on slabs with floating screed system or as resilient under floating dry floorings.

Description

Coupled mat in rolls, composed of granules and selected SBR rubber combined with polyurethane resins (MDI), thermocoupled in a continuous way to crosslinked polyethylene. The peculiarity of the material is due to the fact that it incorporates the advantages of the SBR rubber such as the elasticity and durability with those of the polyethylene such as the adhesive gripping and waterproofing of the SBR rubber.

Therefore the product does not require an additional application of a waterproofing layer before the screed realization given the major presence of polyethylene.

The splices of the material can be easily sealed with adhesive tapes of dBred line.

Technical characteristics

Product name	thickness mm.	thickness rubber mm.	Polyethylene thickness mm.	Rubber specific weight Kg/m ³	Polyethylene specific weight Kg/m ³	Dynamic stiffness MN/m ³	Sound insulation ΔL_w	Roll height mm.	Roll length m.	Rolls per pallet
dBred Duetto F3+3	6	3	3	710	30	53	dB 29	1500	7	15
dBred Duetto F5+4	9	5	4	550	30	35	dB 38	1200	18	6
						EN ISO 29052-1	EN ISO 140 - 7/8			



dBred line F

Acoustic insulation - Rubber SBR/MDI + peeled - Rolls

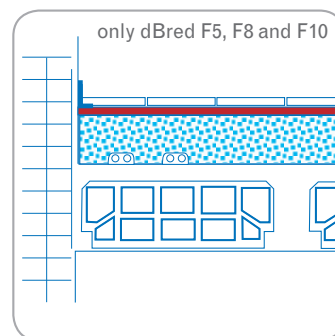
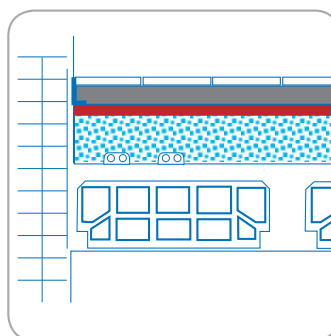
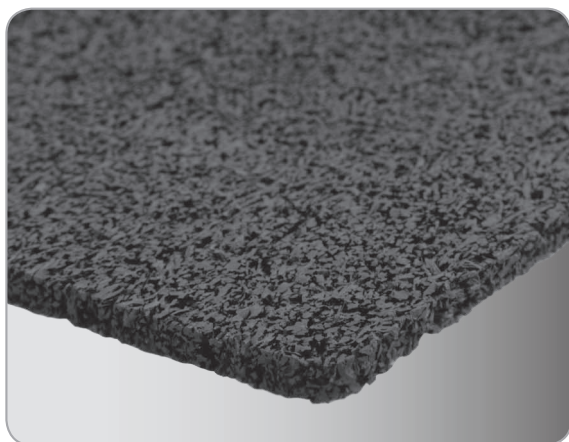

Applications

Impact sound insulation on attics thanks to the floating screed system or an dBred PianoZero® under flooring system with elastic layer directly glued under ceramic or wooden floorings. It can be used for the vibration isolation in general interposing it among planar surfaces.

10

Description

Mat in sheets composed of granules and selected SBR rubber combined with polyurethane resins (MDI) with a density up to 550 kg/m³. The material has an optimal elasticity and mechanic resistance that assures long life and constant acoustic performances.

Technical characteristics

Product name	thickness mm.	specific weight Kg/m ³	Dynamic stiffness MN/m ³	Sound insulation ΔL _w	Roll height mm.	Roll length m.	Rolls per pallet
dBred F3-7210	3	710	78	dB 26	1200	18	16
dBred F5-6010	5	550	54	dB 31	1200	15	16
dBred F8-6010	8	550	39	-	1200	9	16
dBred F10-6010	10	550	37	-	1200	7,5	16
			UNI EN 29052-1	UNI EN 140-7/8			



dBred line F-C

Acoustic insulation-colored-SBR/MDI rubber + peeled PUR-Panels

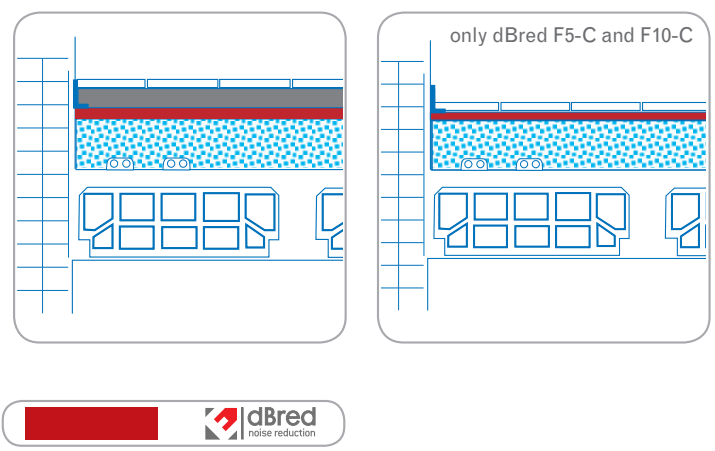
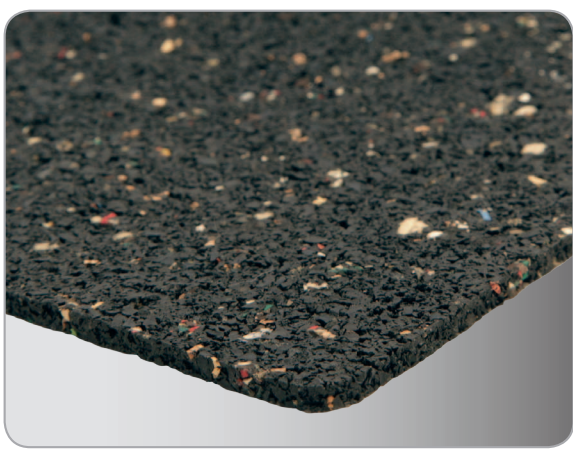

Applications

Impact sound insulation on attics with floating screed or dBred PianoZero® under flooring system with elastic layer directly glued under ceramic or wooden floorings. It can be used for the vibration isolation interposing it among planar surfaces.

Description

Mat in sheets composed of granules and selected SBR rubber combined with polyurethane resins (MDI) with a density of 720 kg/m³. The material has got an optimal elasticity and mechanic resistance that assures long life and constant acoustic performances.

Technical characteristics

Product name	thickness mm.	specific weight Kg/m ³	Dynamic stiffness MN/m ³	Sound insulation ΔL _w	Sheet height mm.	Sheet lenght mm.	Rolls per pallet
dBred F4-C*	4	720	-	-	2300	1150	117
dBred F5-C	5	720	73	dB 20	2300	1150	94
dBred F6-C*	6	720	-	-	2300	1150	78
dBred F8-C	8	720	62	dB 21	2300	1150	58
dBred F10-C*	10	720	-	-	2300	1150	47
			UNI EN 29052-1	UNI EN 12354-2			

* only on request



dBred line FONOTECH

Acoustic insulation – Crosslinked Polyethylene foam – Rolls

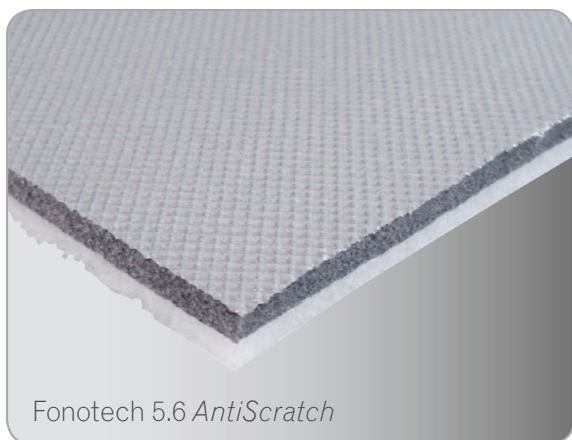

Fonotech 5.6 *AntiScratch*

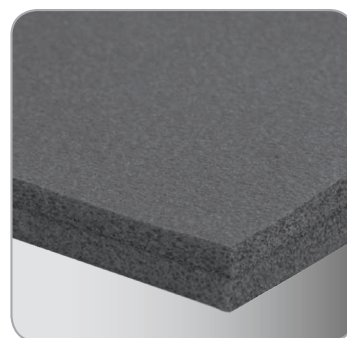
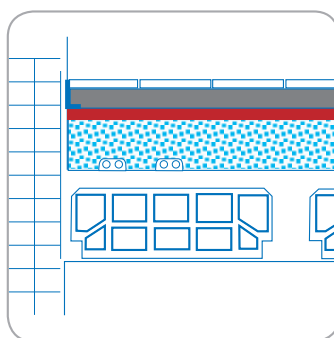

Applications

Impact sound insulation on attics thanks to floating screed system.

12

Description

Mat in rolls of crosslinked polyethylene with a density of 30 kg/m³. This material has an optimal elasticity and practicality of use. The 5-6 PLUS version is composed of crosslinked polyethylene with a thickness of 5 mm combined with fibrebonded and resined polyester fiber.

It is available in the version with aluminised reflective anti-tearing film which is battened to facilitate the application.

Technical characteristics

Product name	thickness mm.	specific weight Kg/m ³	Dynamic stiffness MN/m ³	Sound insulation ΔL_w	Roll height mm.	Roll length m.
Fonotech 4	4	30	73	dB 32	1500	50
Fonotech 5	5	30	52	dB 33	1500	50
Fonotech 10	10	30	19	dB 36	1500	40
Fonotech PLUS 5.6 Battened	10	-	20	dB 36	1500	25
Fonotech 5.6 Antiscratch	10	-	20	dB 36	1500	25

UNI EN 29052-1

UNI EN 140-7/8





SPECIAL REQUALIFICATION

WOODEN FLOATING FLOOR

Suitable for all

Minimum difficulty of execution, few tools to use, and easy to find



SOUNDPROOFING FROM IMPACT NOISE
System

The System is dedicated to the floating wooden coverings in order to reduce the impact noises. It is realised thanks to the application of dBred Professional resilient material under the coating layer.

It develops excellent results both in the reduction of impact noises and in those which are object of intervention.

The floating systems are in fact subjected to the development of noises that are generated within the room during the walking. The use of such coat implies the need of an impact sound insulation and a considerable increase of the environmental acoustic comfort.

Disregarding that issue, noisy wooden floorings would be realised. They would be, characterised by annoying impact noises and in some cases dangerous for the activities of the people within the room.

It is an easy monitoring system ideal to the reconstruction or the regeneration of the buildings. It is easy to realise without the use of particular equipments.

The result is certain as dBred Professional assures optimal performances regarding

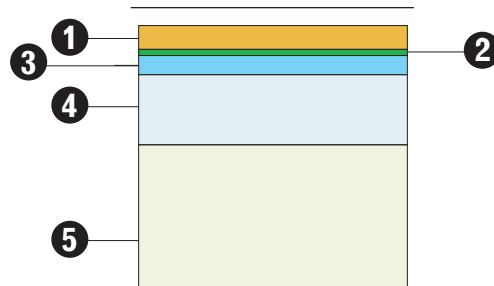

1. Wooden parquet
2. dBred Professional
3. Ceramic coat applied with adhesive cement
4. Sand cement screed thickness 5 cm
5. Insole of the test chamber

the impact resistance, compression and viscous sliding.

Consequently the flooring is able to slide pandering the natural movements of the woods.

The inferior layer of the material is composed of a brake steam that allows breathability but limits the phenomenon of rising moisture.



dBred FELTS line

Acoustic insulation – Natural/synthetic fabrics-rolls

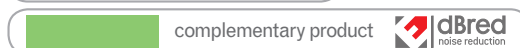
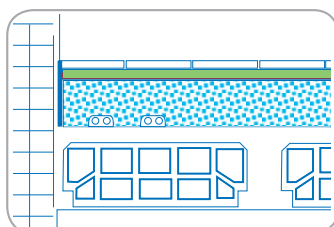
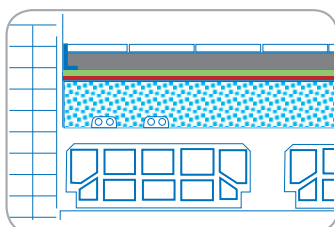
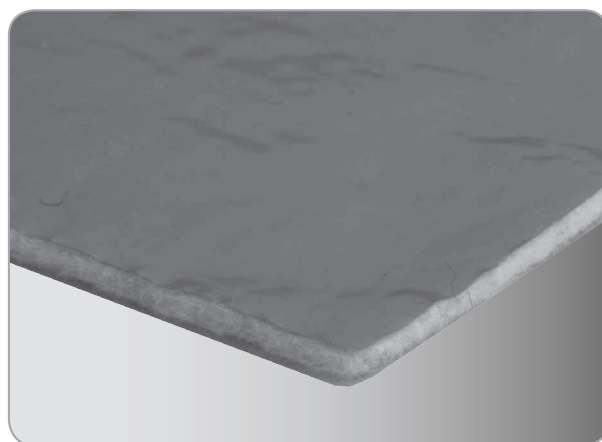
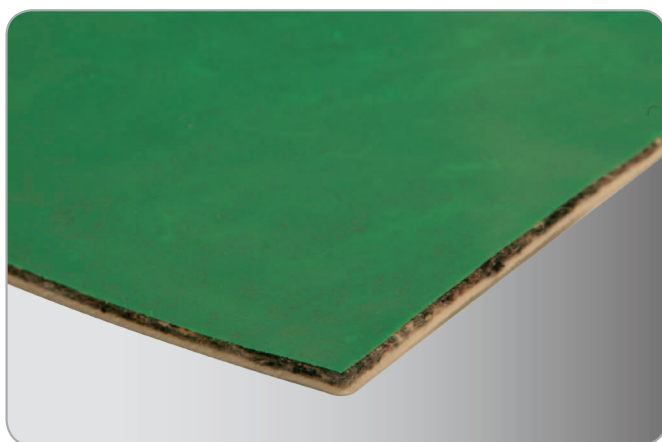

Applications

Impact sound insulation on attics with floating screed system or as resilient under floating wooden floors.

Description

Expert: coupled mat in rolls composed of a PE film of 80 coupled with a polyester fiber. It is used for the installation of the floating parquet or for the waterproofing of rubber mats in presence of cement self-levelling screeds. It is equipped with selvedge for the overlap of the layers of laying.

Professional: Coupled mat in rolls composed of crosslinked Polyethylene, of a recycled fabric and ecologically recomposed in a PE film of 200pm. It is basically used for the application of floating parquet and can also be applied under the screed in the floating screed system. Equipped with selvedge for the overlap of the layers of laying.

Technical characteristics

Product name	thickness mm.	Weight g/m ²	Dynamic stiffness MN/m ³	Sound insulation ΔL_w	Roll height mm.	Roll length m.	Rolls per pallet
dBred Expert	3	380	99	-	1000	30	14
dBred Professional	4	147	60	19*	950	15	16
				UNI EN 29052-116	UNI EN 140-8		

*Test performed in the laboratory under floating laminate flooring



dBred FONOTECH P

Soundproofing mat for the acoustic insulation of partitions

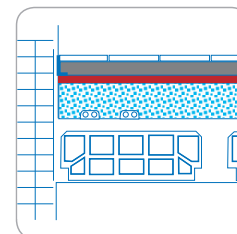
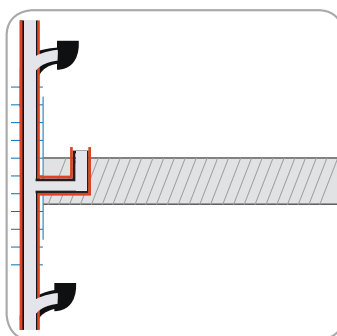
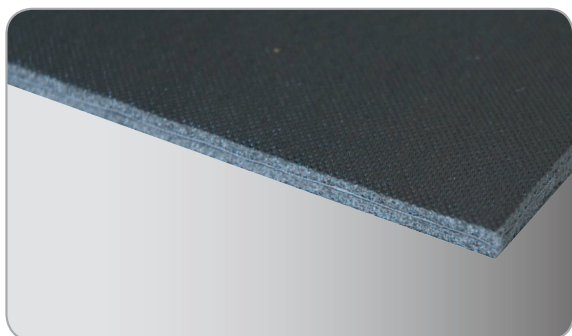

Applications

Increase of soundproofing power of attics and walls or inner courts for plants.

Description

Lead foil of 0,35 mm coupled on both sides with crosslinked polyethylene of 3 mm thick.

Technical characteristics

Product name	thickness mm.	Weight g/m ²	Dynamic stiffness MN/m ³	Sound insulation ΔL_w	Roll height mm.	Roll length m.
Fonotech P	6,35	-	-	dB 24,5	1000	3000
				ISO 140-3		

15

dBred FONOTECH ECO P

Soundproofing mat for the acoustic insulation of partitions

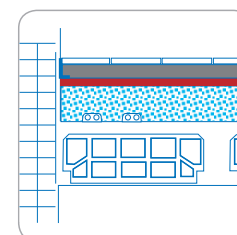
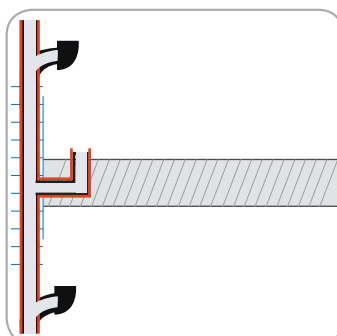
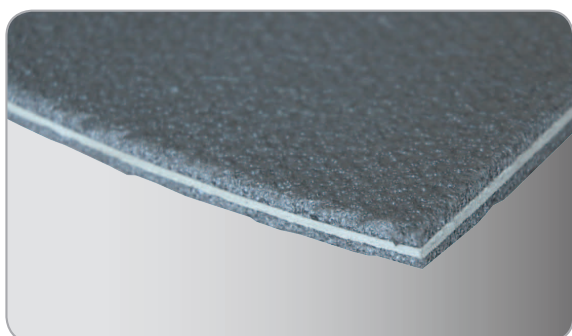

Applications

Increase of soundproofing power of attics and walls

Description

Polyolefin film coupled on both sides with crosslinked polyethylene of 3 mm thick.

Technical characteristics

Product name	thickness mm.	Weight g/m ²	Dynamic stiffness MN/m ³	Soundproofing R_w	Sound insulation ΔL_w	Roll height mm.	Roll length m.
Fonotech ECO P	8	-	-	dB 25	dB 18	1200	3000
				ISO 140-3	ISO 140-8		





SPECIAL REQUALIFICATION

dBred PIANO ZERO®

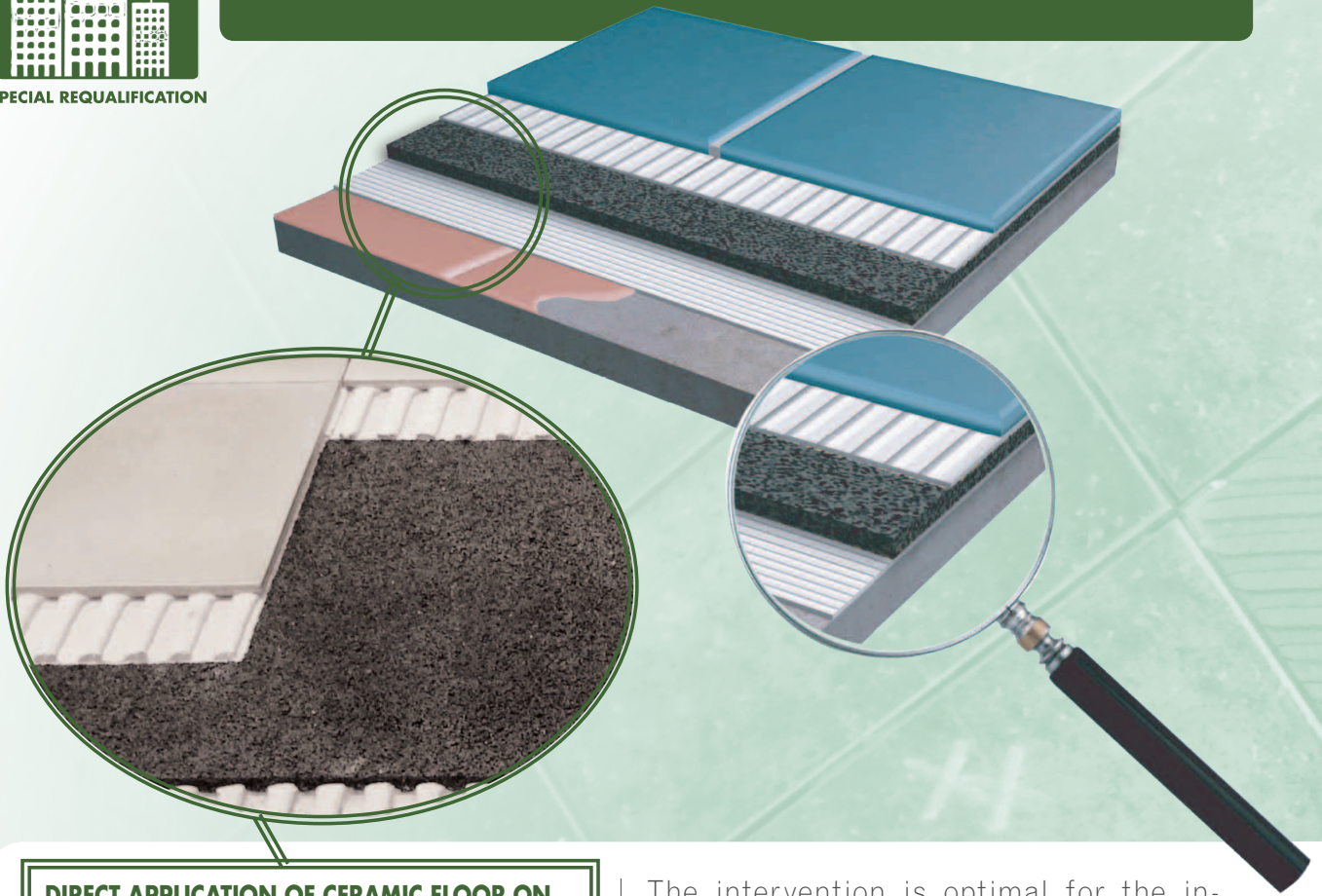

DIRECT APPLICATION OF CERAMIC FLOOR ON dBred ACOUSTIC MATS

Impact sound insulation that provides the direct gluing of the ceramic on the mats of the dBred range.

It is realisable in reduced thicknesses from cement surfaces or pre-existent floors. It is particularly suited to reconstruction interventions and in the reduction of the structural transmission of impact noises on stairs. The whole cycle of application needs a cement adhesive suitable to the floor.

Surfaces suitable for application

Edilteco lightweight single layer substrates:

- Politerm Blu (cement 300/350kg/m³), Isolcap Fein, Isolcap XX, Isolcap Max, Isolcap Speed
- Traditional cement screeds or self levelling
- Existent ceramic floor

The intervention is optimal for the insulation of structural elements made of reinforced concrete such as stairs and landings or common passages even if already existent.

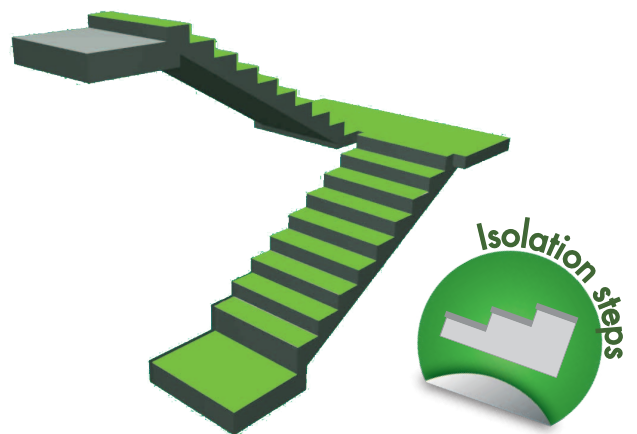

Technical characteristics

- Strain resistance: > 0,4 N/m² (EN 1348 - EN12004)*.
- Impact sound insulation: values of ΔL_w up to 17 dB (UNI-140-7).
- Load to 25% of the crush: 0,28 N/mm² (EN ISO 3386-2)



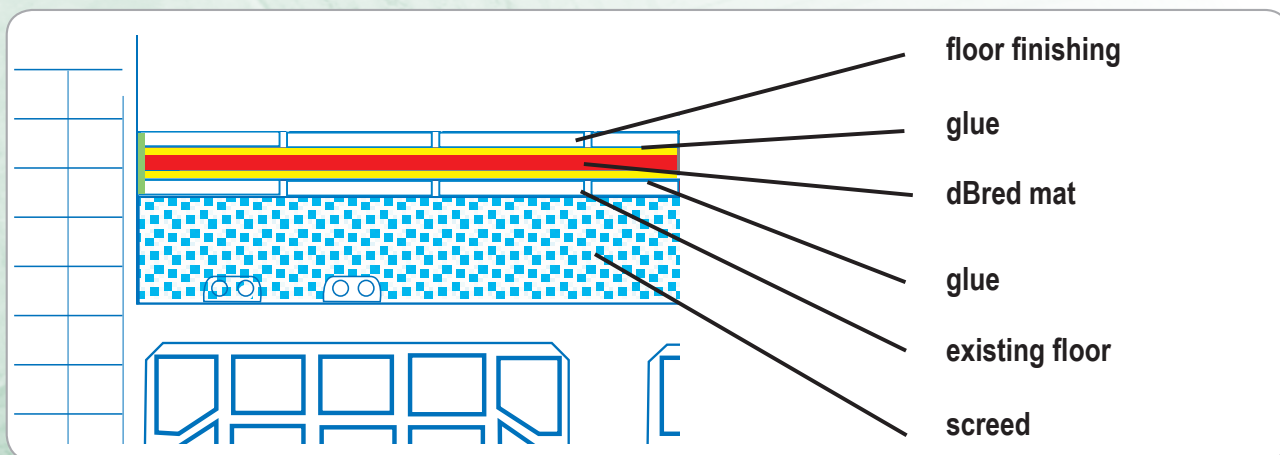

Exemple of stratigraphy on existing slab

SEQUENCES of dBRED APPLICATIONS

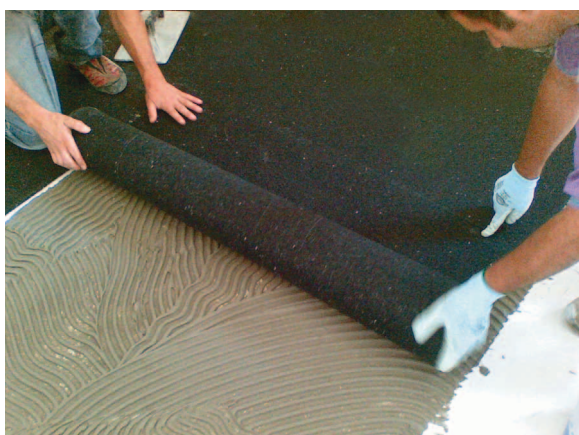

1. Glue and dBred mat application



2. Passage with load roller



3. dBred mat applied in a continuous way with AD series perimetric stripes



4. Ceramic floor application



dBred Stripes LF5 Super & Economy*

Perimetric L stripes – adhesive - polyethylene

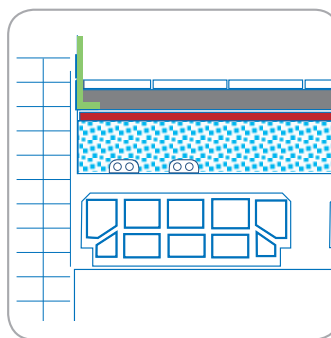
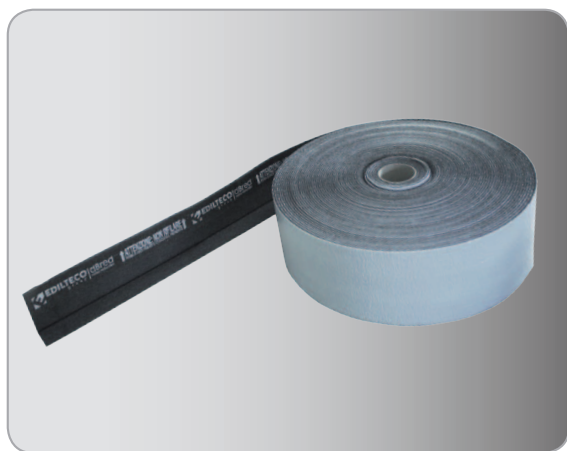

Applications

Impact sound insulation on attics with floating screed system. It is perimetrically applied to protect all the vertical partitions and the other elements during the installation of the floating system.

18

Description

Adhesive stripes made of expanded polyethylene equipped with hot creasing in order to facilitate the L bending and with screen printed application instructions. The stripe is continue and takes easily the L shape during the application, maintaining a part near the vertical elements and the other applied in an horizontal way on the mat. The protective film of the adhesive can be partially removed leaving protect the upper extreme. This makes possible the easy removal of the exceeding part over the floor without affecting the plasters on the walls with the adhesive.

Technical characteristics

Product name	thickness mm.	Vertical part height mm.	Horizontal part length mm.	Roll height mm.	Roll length m.	Rolls per pallet
LF5 10+5 Super/Economy*	5	100	50	150	50	10
LF5 15+5 Super/Economy*	5	150	50	200	50	7

* The Economy version differs from the Super one only for the description that includes logo and application methods.



Adhesive Tapes R-Stick Green

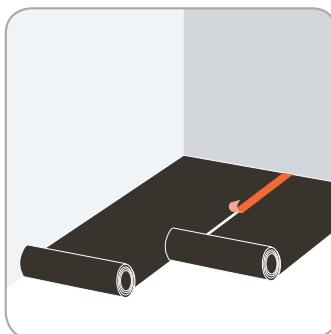
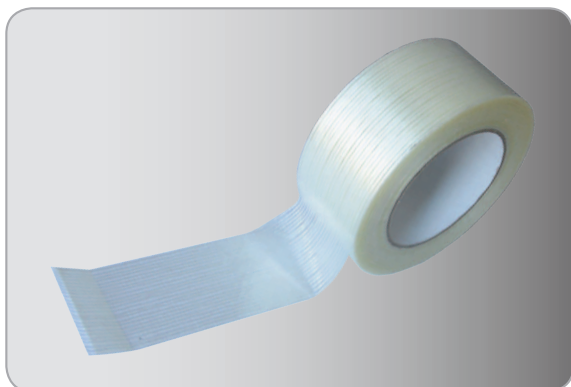

Applications

Junction of the SBR rubber mats joints and all the mats of dBred range.

Description

Adhesive tape with rubber thermosetting glue with support of polyester film.

Technical characteristics

Roll width mm.	Roll length m.	Rolls per pallet
50	50	24

19

Adhesive Tapes R-Stick Butile

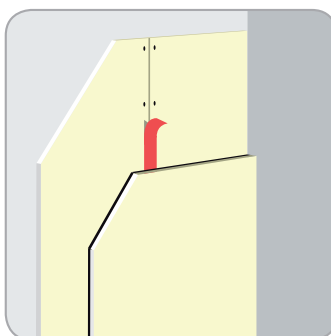
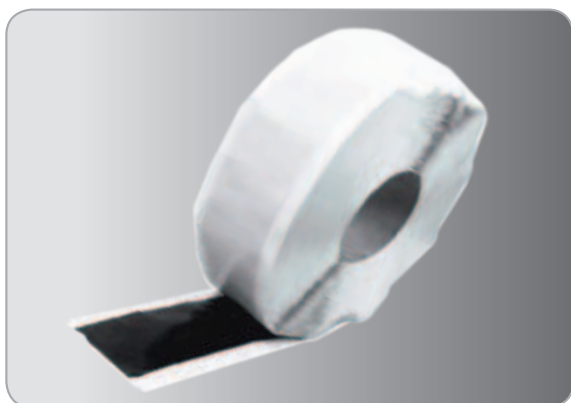

Applications

Junction of the SBR rubber mats joints and closure of the junctions in the dry realizations.

Description

Butylic rubber double-sided adhesive tape with protective film.

Technical characteristics

thickness mm.	Roll width mm.	Roll length m.	Rolls per pallet
1	40	80	4



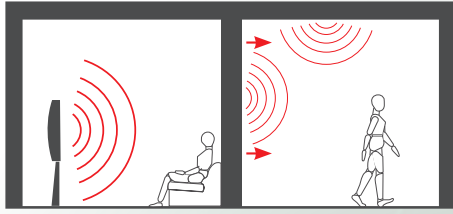

ACUSTIC INSULATION from AIR TRANSMISSION NOISES

The increasing of the soundproofing power of the houses' partitions, offices or buildings designated for other intended uses is necessary in order to avoid the spread of the noises coming from an inhabited unity during the daily activities in the other neighboring units.

It is therefore necessary to define the most suitable acoustic system in order to obtain the insulation provided by the project or those necessary for the respect of the values expected from the current legislation.

Among all the partitions including units subjected to verification and designed for the phono insulation, the intervention on vertical dividers result to be more important.

This is due to their conformation.

The bricks which are very spread in building, result to be light and poorly acoustically performing for the required performances.

Consequently their performances have to be increased with soundproofing materials. For double walls is essential to intervene inserting materials into the interspace while for the single wall is necessary to realize pannellings into the walls adjacent to other walls.

The pannelling can be extended to the ceiling through the horizontal structures if they would present low soundproofing power.

The efficacy and the correct functioning

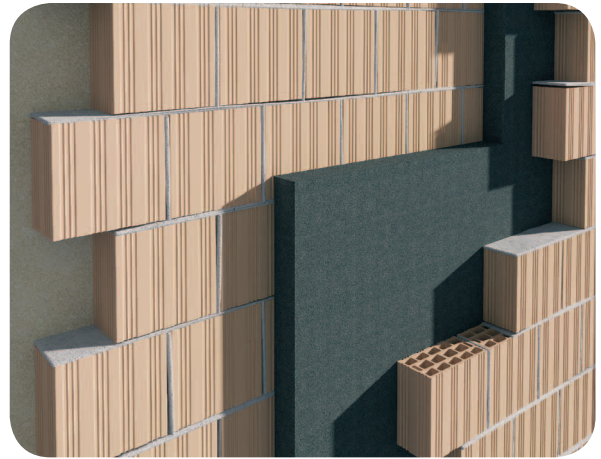

of an acoustic system for vertical partitions depend on two fundamental factors.

The first is the correct designing finalized to the chose of the material suited to the stratigraphy of the attic and the second is the correct application of the system. This is realised by carefully following the application instructions for the materials dedicated to the acoustic insulation, while for the brick elements it is addressed to their realisation. In order to develop the maximum of their acoustic performances, therefore those of the whole system, the pannellings have to be realised with the continuity of the mortar shrinkings both in vertical and in horizontal and the eventual breaks for the plant passages will have to be rehabilitated with the insertion of cement materials.

dBred line W

Acoustic insulation – high density SBR/MDI rubber – panels

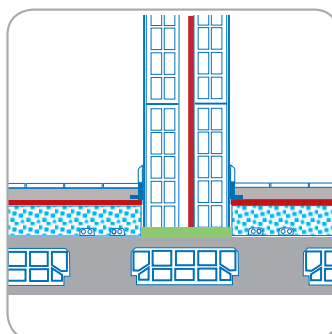
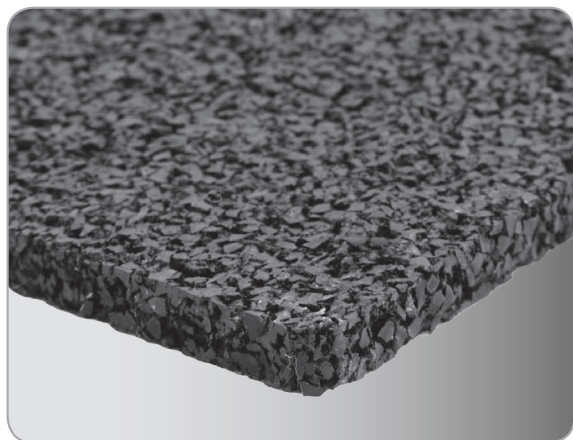

Applications

Acoustic correction of masonry partitions and external existent walls and/or of new conception.

Description

Single layer panel with soundproofing function made of selected SBR rubber granules bounded with high density polyurethanic resins (MDI).

Technical characteristics

Product name	thickness mm.	specific weight Kg/m ³	Panel dimension mm.	Weight Kg/m ²	Panels per pallet
dBredW10	10	804	1200x1200	11,58	80
dBredW20	20	804	1200x1200	23,15	40

Systems certificated according to UNI EN 140-3:

Description	R _w (dB)	Test report	Institute
Double hollow brick masonry of 12+12 cm, externally and internally plastered – dBred W20 applied with glue.	64	M1.05.TL.645/23463	Modulo Uno S.p.A.
Double block masonry YTONG of 8+8 cm, externally plastered dBred W20 applied with glue.	58	N° 230472 del 14/09/2007	Istituto Giordano S.p.A.
GASBETON Evolution 500 Double masonry of 10+8 cm, externally plastered – dBred W20 applied with glue.	56	M1.09.RFIS.354/37438	Modulo Uno S.p.A.
Double hollow brick masonry of 10+8 cm, externally and internally – dBred W10 applied with glue.	53	10-0380-07	I.N.R.I.M.



dBred Stripes F3

Underwall stripes 3mm, SBR/MDI rubber – rolls

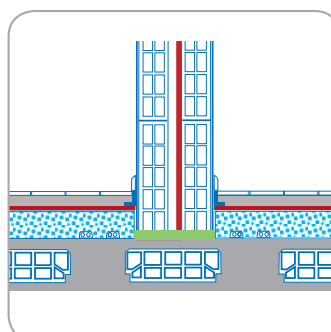
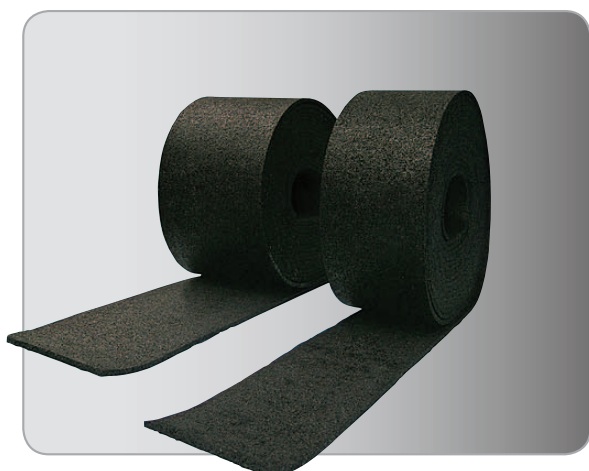

Applications

Impact sound insulation on attics with floating mat system. It is parametrically applied to protect all the vertical partitions during the application of the floating mat or only during the installation of the floating coat.

Description

Underwall stripes in rolls composed of granules and selected SBR rubber bounded with polyurethane resins (MDI) with a density of 710 kg/m³. This material has an optimal elasticity and mechanic resistance and assures long lasting acoustic performances. Dynamic rigidity 78 MN/m³ (UNI EN 29502-1).

Technical characteristics

Product name	thickness mm.	Roll height mm.	Roll length m.	Rolls per pallet	Dynamic stiffness MN/m ³
dBred F3-F10	3	100	18	160	78 (EN ISO 29502-1)
dBred F3-F15	3	150	18	96	
dBred F3-F20	3	200	18	72	
dBred F3-F25	3	250	18	58	
dBred F3-F30	3	300	18	44	
dBred F3-F35	3	350	18	36	
dBred F3-F40	3	400	18	36	
dBred F3-F45	3	450	18	32	
dBred F3-F50	3	500	18	24	



CORRECT APPLICATION UNDER WALL STRIPES "F series"

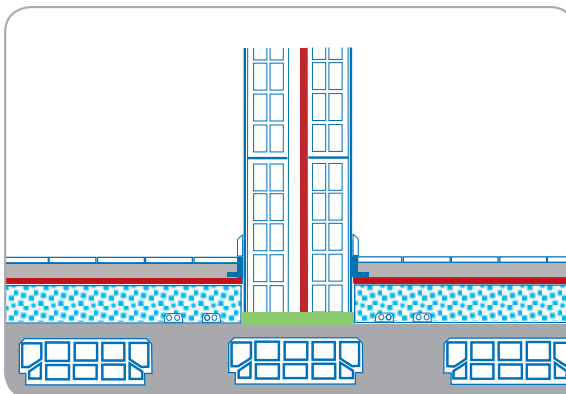

1. Verification of the laying surface

The application area of the SBR rubber mat dBred F will have to be glide and free of any rubble coming from prior working phases or roughness in order to enable the mechanical stability and the correct functioning of the material.

2. Application of the underwall stripe

The stripe will be applied on the nude attic before the panning realization. Its length will have to be able to contain the pannelings and the related plasters.

The first line of bricks will have to be applied on the stripe with the same cement mortar which will be used for the realization of the wall.

In case of double walls, it will be necessary to apply more stripes to contain every brick and its plasters or a single stripe able to contain the thickness of the brick and its plasters.

The application of the bricks will have to be continuous with mortar splines both horizontally and vertically.





TERMOACUSTIC REQUALIFICATION

SPECIAL REQUALIFICATION

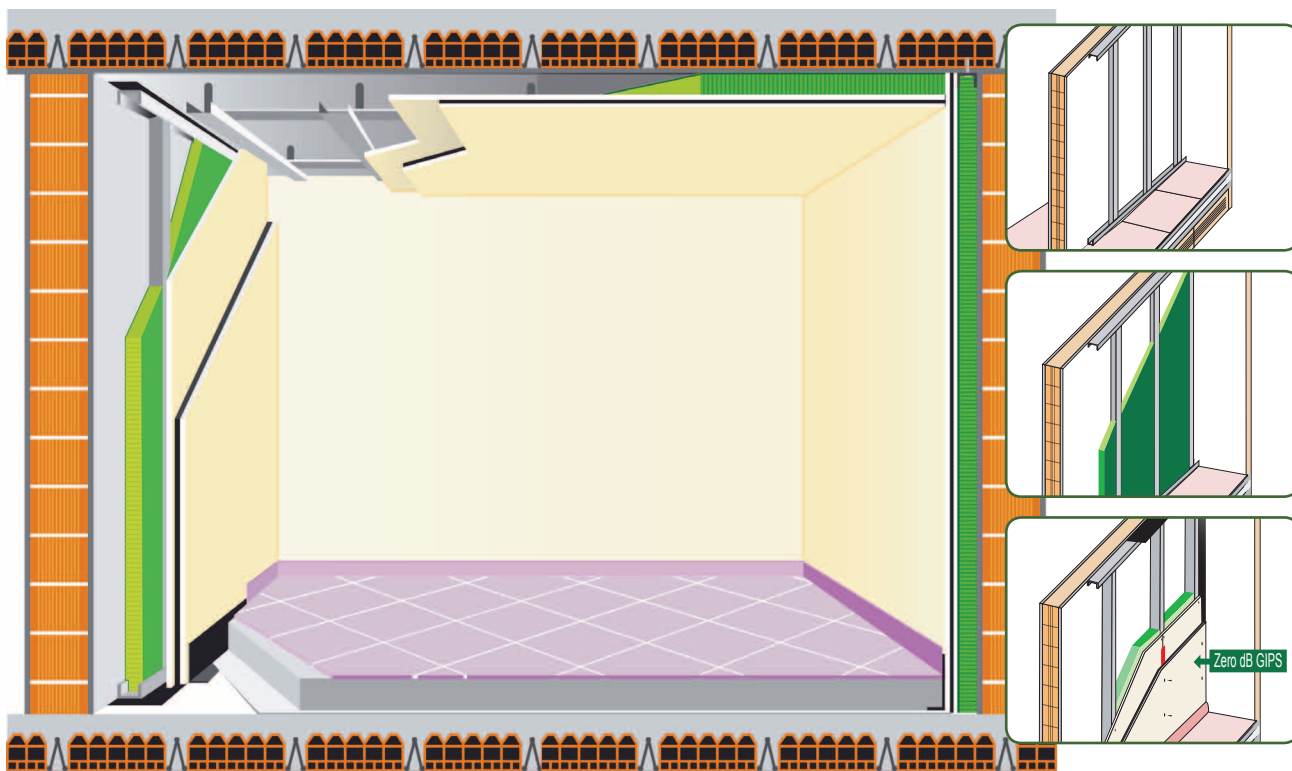

24

Thanks to the usage of Zero dB GIPS panels we realize coats for walls adjacent to their walls or adjacent to the ceiling for the thermoacoustic requalification of partitions brick partitions. Developing in a few centimetres they are particularly suitable for the renovations or for buildings at high acoustic performances.

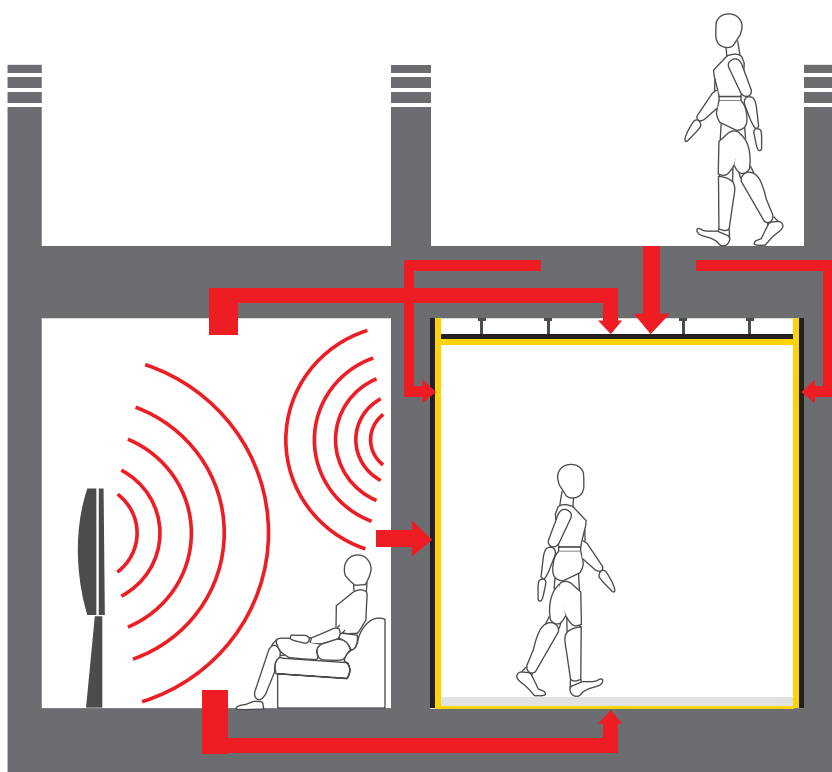

Interventions of panning application

They are finalised to insulate a residential area from the other neighboring areas that can transmit their inside noises through the structural elements which are connected among them.

The intervention can be finalised to reduce the passage to a single transmission way or to the reduction of all the possible transmissions, realizing a continuous system over all the surface.



SYSTEM 1:
Direct panneling

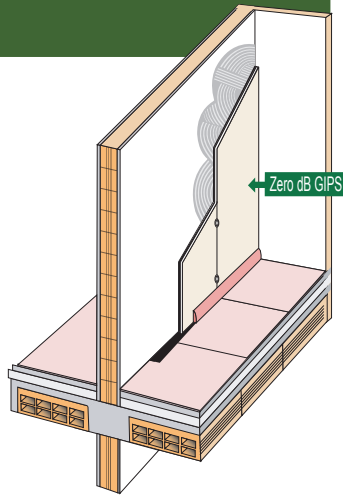

The application of Zero dB GIPS panels is made directly on the wall through Ecap ADP glue and nylon dowels, according to what indicated in the application data sheet.

The superficial finishing will be realised with products for panels made of gypsum.

Total thickness of the coat: 25 mm

Certificate	R_w	ΔR_w
With Zero dB GIPS 150-10 panels of 25 mm thickness, on brick wall of 12 cm plastered on both sides.	53 dB	7 dB

Laboratory data according to UNI EN 10140-1 and 2

SYSTEM 2: in semi-adhesion to the wall on supports of 15x20 mm thickness

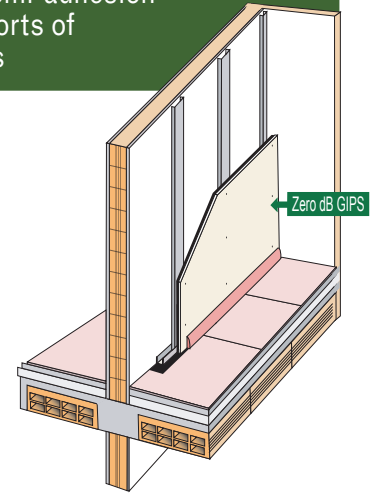

The application of Zero dB GIPS panels is made through self-tapping screws on supports of 15x50 mm placed to step of 600 mm and fixed for points to the wall through suitable hangers with metal dowels. The superficial finishing is realised with products for panels made of gypsum.

Total thickness of the coat: 35/40 mm

Certificate	R_w	ΔR_w
With Zero dB GIPS 150-5 panels of 20 mm thickness, on brick wall of 12 cm plastered on both sides.	52 dB	6 dB
With Zero dB GIPS 150-10 panels of 25 mm thickness, on brick wall of 12 cm plastered on both sides.	55 dB	9 dB

Laboratory data according to UNI EN 10140-1 and 2

SYSTEM 3: to wall built adjacent to another wall, with freestanding metal structure, profile 27x50 mm

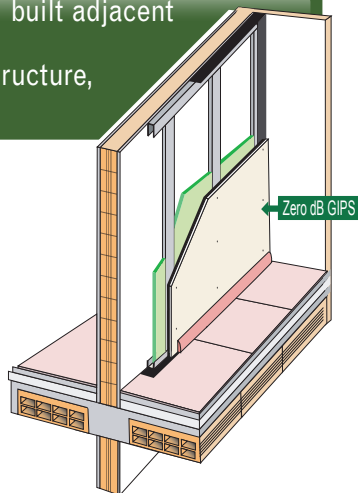

The application of Zero dB GIPS panels is made through self-tapping screws on freestanding metal structure, with "C" profiles 27x50 mm to step 600 mm and "U" perimeter guide 27x30 mm perimetally fixed with metal dowels and interposed to dBred F stripes. The superficial finishing is realised with products for panels made of gypsum.

Total thickness of the coat: 50 mm

Certificate	R_w	ΔR_w
With Zero dB GIPS 150-5 panels of 20 mm thickness, on brick wall of 12 cm plastered on both sides.	61 dB	15 dB

Laboratory data according to UNI EN 10140-1 and 2

SYSTEM 4: to wall built adjacent to another wall, with freestanding metal structure, profiles 50x50 mm

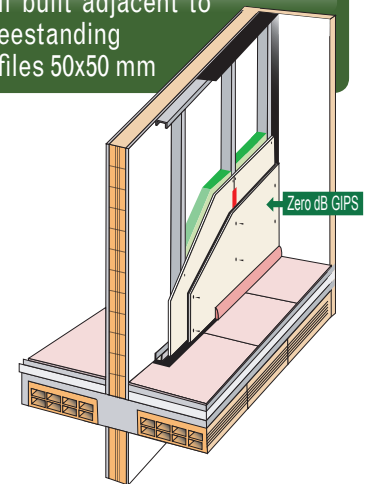

The application of Zero dB GIPS panels is made through self-tapping screws on freestanding metal structure, with "C" profiles 50x50 mm to step 600 mm and "U" perimeter guide 50x400 mm perimetally fixed with metal dowels and interposed to dBred F stripes. The superficial finishing is realised with products for panels made of gypsum.

Total thickness of the coat: 85 mm

Certificate	R_w	ΔR_w
With Zero dB GIPS 150-10 panels of 25 mm thickness, on brick wall of 12 cm plastered on both sides.	63 dB	18 dB

Laboratory data according to UNI EN 140-3



dBred line ZERO dB GIPS

Coupled acoustic insulation – High Density SBR/MDI rubber + Plasterboard - Panels

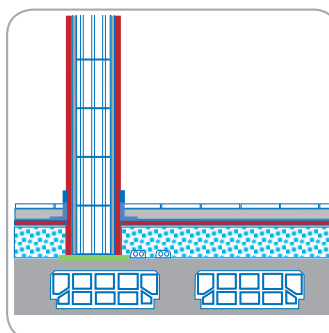
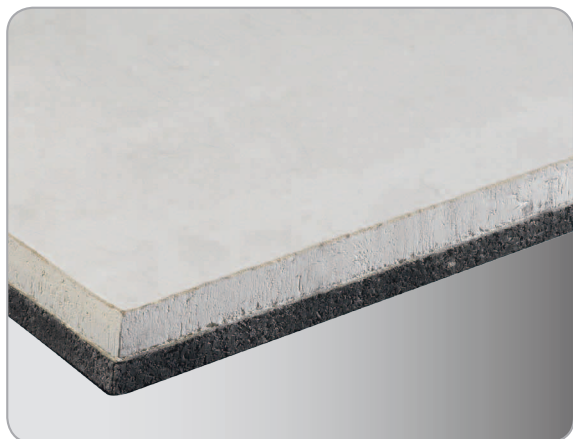

Applications

Acoustic correction of horizontal and vertical partitions and external existent masonries and/or of new conception.

Description

Special coupled panel made of a gypsum slab with panels of selected SBR rubber granules bounded with polyurethane resins (MDI). It is characterized by a high soundproofing power and reduced resonance phenomenon. Fire resistance class Bs1, according to UNI EN 13501-1

Technical characteristics

Product name	thickness mm.	specific weight rubber Kg/m ³	Panel dimension mm.	Reaction to fire	Weight Kg/m ²	Panels per pallet
Zero dB GIPS150-5-M	20	804	1200x2000	Bs1,d0	16,92	28
Zero dB GIPS150-10-M	25	804	1200x2000	Bs1,d0	20,94	23
*Zero dB GIPS125-5-M	17,5	804	1200x2000	-	13,22	36
*Zero dB GIPS125-10-M	22,5	804	1200x2000	-	17,24	28
				UNI EN 13501-1		

*on request



ECAP ADP

Glue powder for rubber panels.

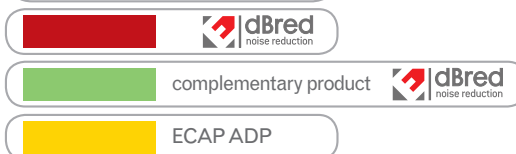
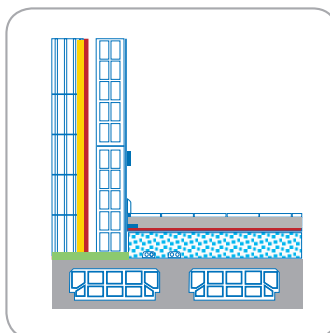

Applications

Glue powder for panels W line and ZERO dB GIPS.

Description

Glueing and levelling powder at cement base for manual and mechanic application.

Technical characteristics

Product name	Bag weight Kg.	Panels per pallet
ADP	25	54

N.B. The brush has to be doweled as per the below scheme.

Installation schemes of brush with glue and dowels

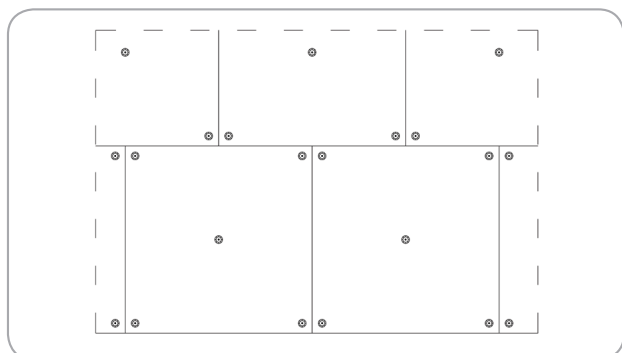

Application of W20 series panels

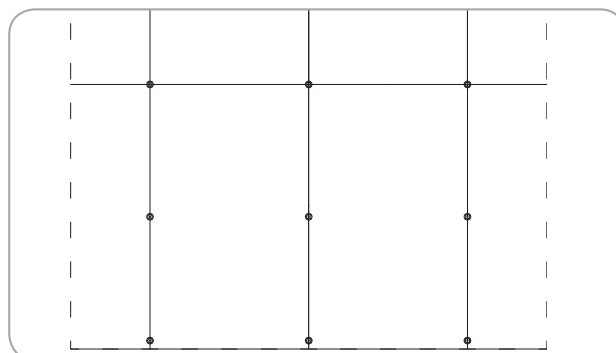

Application of Zero dB Gips series panels



Gips RUBBER 01

Antivibrating hangers

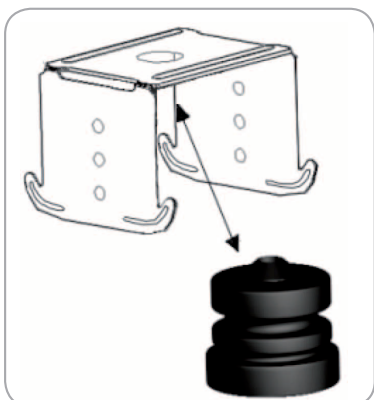

Applications

- Insulation of slab ceilings.
- Fast connection to the steel profiles for ceilings.

Description

- Antivibration hangers for slab ceilings

Technical characteristics

See technical data sheet

Gips RUBBER 02

Antivibrating hangers

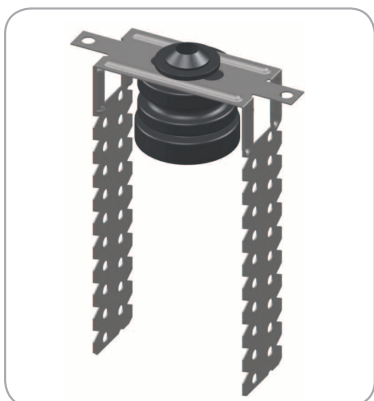

Applications

- Antivibrating suspension of slab ceilings.
- Antivibrating suspension of air ducts and conditioner.

Description

- Antivibration hangers for slab ceilings

Technical characteristics

See technical data sheet

Gips FOAM

Antivibrating hangers

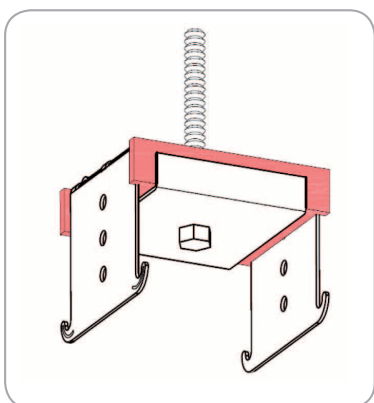

Applications

- Insulation of slab ceilings.
- Fast and easy connection to the steel profiles for slab ceilings.

Description

- Antivibration hangers for slab ceilings with Regufoam®.

Technical characteristics

See technical data sheet



RUBBER 01

Antivibrating hangers



Applications

- Suspensions of machineries (air conditioner, fan, etc.).
- Suspensions of soundproofing slabs.

Description

- Multi purpose Antivibrating supports

Technical characteristics

See technical data sheet

RUBBER M01

Antivibrating hangers



Applications

- Antivibrating suspension of slab ceilings.
- Antivibrating suspension of air ducts and conditioner.

Description

- Multi shape antivibrating suspensions with dBred RUBBER 01

Technical characteristics

See technical data sheet

Gips FOAM-M

Antivibrating hangers

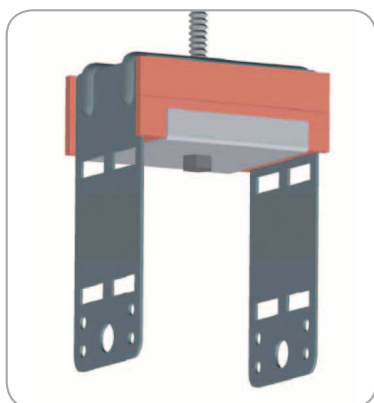

Applications

- Antivibrating suspension of slab ceilings.
- Antivibrating suspension of air ducts and conditioner.

Description

- Multi shape antivibrating suspensions with Regufoam®

Technical characteristics

See technical data sheet



Since 1981, Edilteco Group, pursuing a process of continuous development, has set as priority objective the research for the best compromise between long-term product performances and its cost.

The same philosophy has led to the birth of dBred acoustic division, and the subsequent imprinting on the market, characterizing it through the research of the best certificated performances and the maximum engagement in the fulfillment of the requirements provided by the current legislation concerning the protection and conservation of the environmental acoustic comfort. For this reason, the products present in this catalogue that we are delivering to you, have been widely and minutely tested on site by many accredited laboratories throughout the national territory, with results that have always been proportionated to the expectations of designers and construction companies.

In an increasingly competitive and open to innovation market, but especially deficient in terms of regulations on the characterization of insulating materials, our effort is not only to provide precise and professional solutions, but also to inform and make culture on the real problems related to acoustic comfort and to the use of materials with uncertain potential performance over the medium and long term. Advanced techniques and investments for the expansion and improvement of Edilteco Group know-how, allow us to guarantee the maximum in terms of reliability, performances and long life, to those who have already chosen us for our expertise, and to whom that will do it in the warranties future. Who chooses dBred knows he can count on an efficient technical support both in construction and in design, guaranteed by various certifications on site, but, above all, has the perception of the high sense of responsibility in choosing the most suitable solution to his problem.

An aware choice.

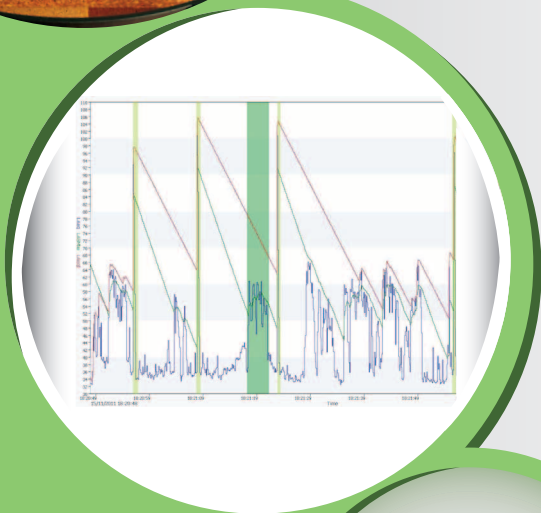

PLANNING

Free assistance service to the designing of acoustic and vibration isolation systems aimed at the development of the best solution according to the construction requirement.

The dialogue with the technical service is quickly and effective thanks to a series of electronic forms of pre-dimensioning request.

TRAINING

A technical training with appropriate contents will be addressed to companies, practitioners, resale and sale networks regarding the acoustic subject in building, vibration isolation systems and correct material application.

ACOUSTIC TESTS

Thanks to a qualified network of competent technicians competent in Environmental Acoustic according to the current legislation 447/95 we are able to test acoustically according to DPCM 5-12-97 the passive acoustic requirements of the buildings.

ASSISTANCE

Technical assistance is addressed to the construction site for free inspections, acoustic cognitive and experimental investigations, training for the staff employed to the product application and monitoring on site for all laying phases.

PRODUCTS DEVELOPMENT

Development of materials and acoustic or vibration isolation systems certified as per customer specific requests.

Ph. +39 0535 82161

Fax +39 0535 82970

e-mail: tecnico.dbred@edilteco.it

All the indications provided in this technical data sheet are purely approximate and not binding for legal purposes. The data listed has been gathered from laboratory tests and it hence follows that in practical applications on buildings sites the final characteristics of the products may be subject to substantial variations depending on the meteorological conditions and the installations. The user must always check suitability of the product for its specific use, undertaking all liability implicit in and deriving from use of the product, as well as comply with all the methods and instructions for use generally referable to "workmanlike" execution. Edilteco S.p.A. reserves the right to change the contents of this technical data sheets on its final judgements. The spreading of this data sheet through any media, supersedes and cancels the validity of any other technical data sheet previously published.

© Copyright **EDILTECO S.p.A.**
Marketing division

The manufacturer reserves the right to make changes without prior notice
-Non authorized copy is forbidden-



EDILTECO S.p.A. - via dell' Industria, 710 - 41038 San Felice sul Panaro (MO) - Italy
Tel: +39 0535 82161 - Fax: +39 0535 82970 - info@edilteco.it - www.edilteco.it